



Interior Molding & Custom Shapes Catalog

8585 Miramar Place, San Diego, CA 92122
(858) 455-1274

Table Of Contents

<u>Subject</u>	<u>Pg</u>
About Our Product.....	2
Crown Molding	4
Cove Molding	9
Casing and Trim	12
Custom applications.....	15
Columns	16
Domes and Niches	18
Fireplace Surrounds	19
Molding Profile Index	20

About our product...

PCF/Inside specializes in decorative products suitable for a variety of interior applications such as moldings, columns, mantels, domes and niches. PCF/Inside is an affiliate of Pacific Coast Foam, a leader in the production of expanded polystyrene shapes (EPS) for the building community.

An economic alternative

Compared to other decorative molding products such as wood, precast concrete or cast fiberglass, PCF/Inside moldings typically represent cost savings both in material and installation. The molding can be prefinished, or installed and then painted in place as part of the drywall process.

Cost savings are greatest in moldings of 6" in height or greater. Where wood moldings require a build-up of several profiles with nailing strips and multiple cuts per length, EPS moldings can be cut in one piece to virtually any size. For example, a 12" wood cove or crown molding can be prohibitively expensive for most jobs; EPS allows the use of economical material and one step installation by a drywall contractor, painter or laborer instead of a skilled finish carpenter.

The manufacturing process

Sold finish ready, the raw forms are made by state-of-the-art computerized equipment that cuts large blocks of expanded polystyrene foam into the standard molding profiles and shapes shown in this catalogue, or to any specification you provide.

Depending on the intended application, the cut material is typically wrapped with fiberglass mesh, coated with a gypsum based, acrylic reinforced material and finish to a smooth, paint ready finish.

Installation and maintenance

Installation is simple with our recommended adhesive product, which can be used in conjunction with finish nails or screws. Touch-up is easy using our recommended product to fill nail holes and joints. Butt or miter joints can be cut with the same tools you would use for wood moldings. For ease of application, we also offer prefabricated inside and outside corners to match your molding profiles.

PCF/Inside products come in three densities. One pound foam for low impact areas, such as crowns, two pound foam for areas that might receive some impact, such as residential chair rails, or three pound density for high traffic areas. Minor damage can be easily patched and repaired with any PCF/Inside recommended material.

Ordering

Whether you use our standard moldings or need to customize, ordering is fast and simple. We can usually have product ready within five to seven working days. For standard moldings just call us with the profile number, size and quantity and we can quote you over the phone. We also have a price list available for our standard products so that you can calculate your own job costs. For custom work, please fax or mail us your plans and specs and we can usually quote you within twenty four hours. We also provide professional design services when you are just not sure what to use on your project. Take advantage of our experience to make your interior jobs stand out from the crowd.

An Environmentally Sensitive Product

When coated, EPS products are not affected by UV light, and they are moisture, mildew, and insect resistant. Its manufacture does not release chemicals that deplete the ozone and it can be recycled into a variety of products.

Warrantee

PCF/Inside moldings are warranted against defects in workmanship or material. Provided that installation is done according to the manufacturer's written specifications, using approved materials, PCF will replace product that proves defective in workmanship or materials.

Specify PCF/Inside EPS moldings...

To ensure the finest quality EPS coated moldings on your design project use the following call out on your plans and specs:

Paint ready finish over reinforced fiberglass mesh with Foam Coat ICBO approved no. 5161 over [1lb., 2lb.or 3lb.] density EPS by PCF/Inside, 8585 Miramar Place, San Diego, CA 92121. (858) 455-1274.

Crown Molding

Crown Molding & Cove Molding are interchangeable. Product comes as notched or straight back as shown in catalog unless otherwise noted.

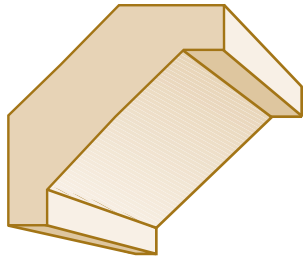

101

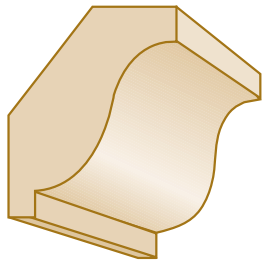
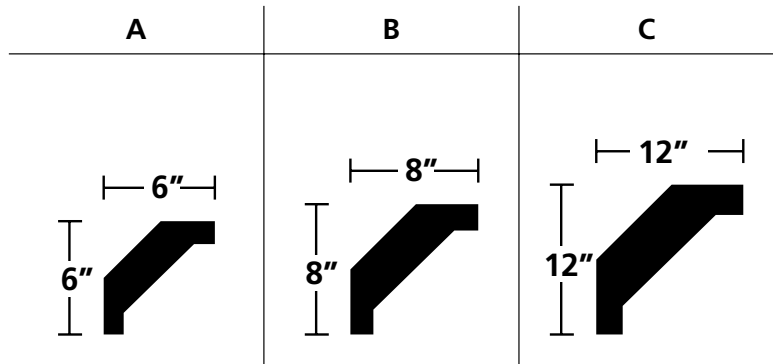

102

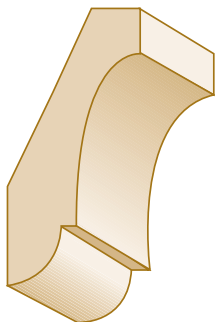
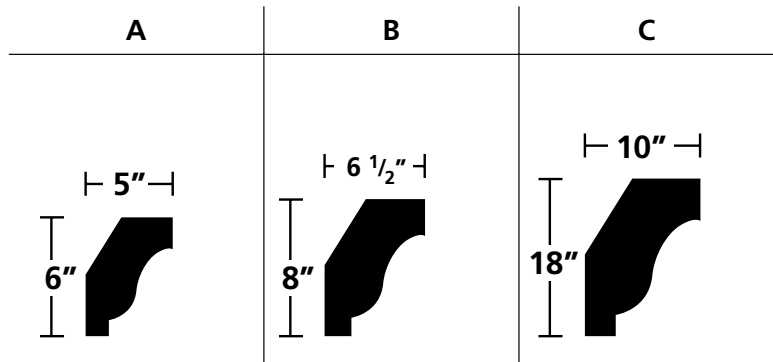

103

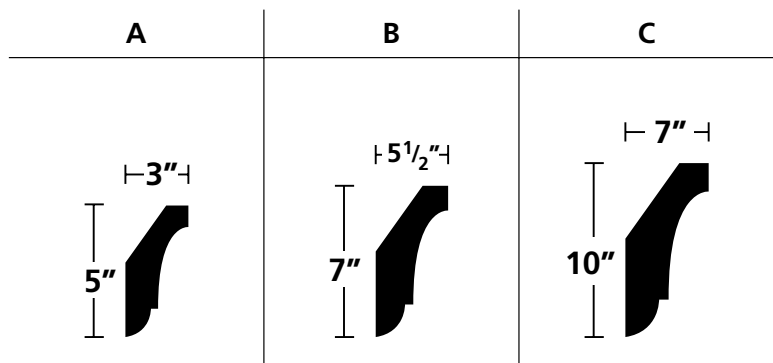

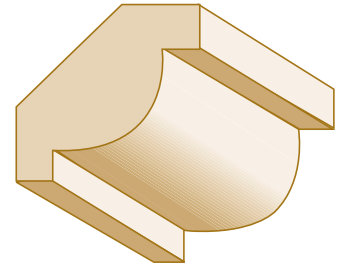
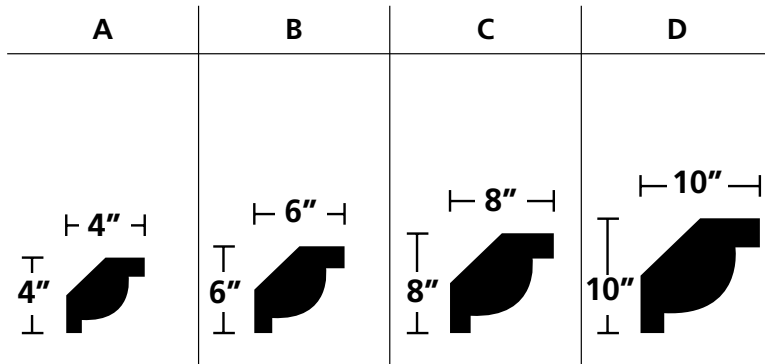

104

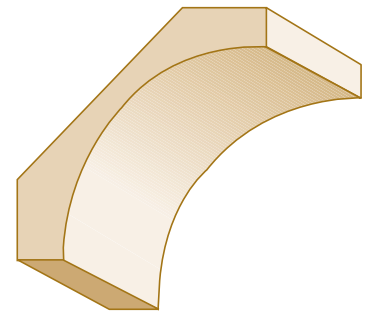
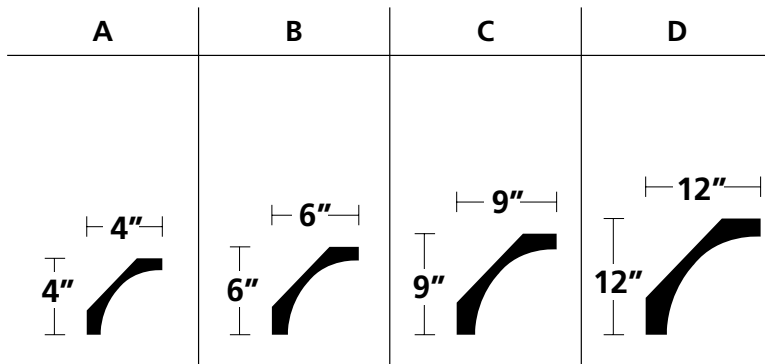

105

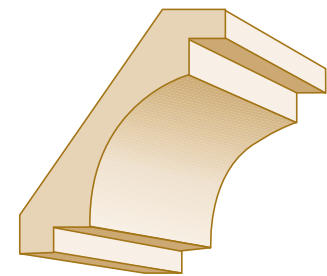
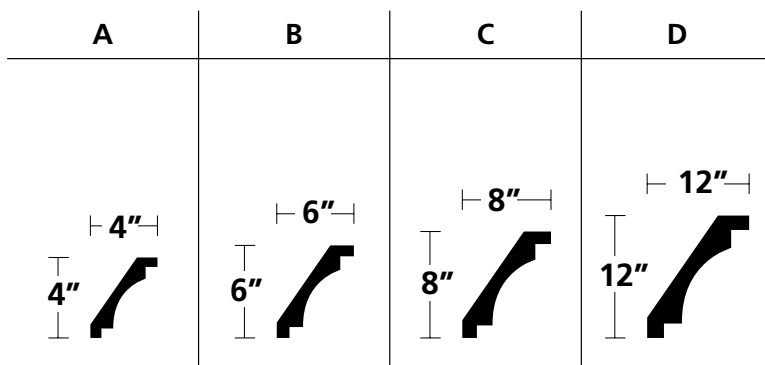

106

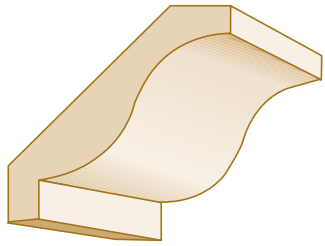

107

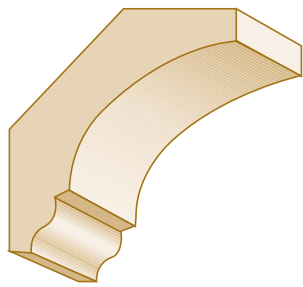
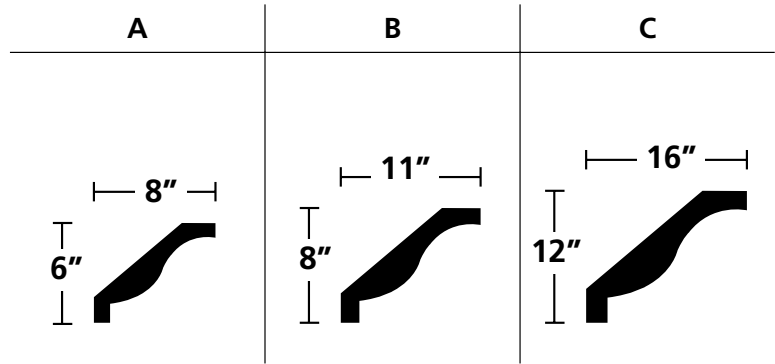

108

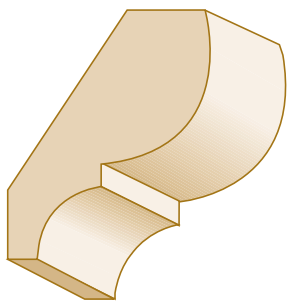
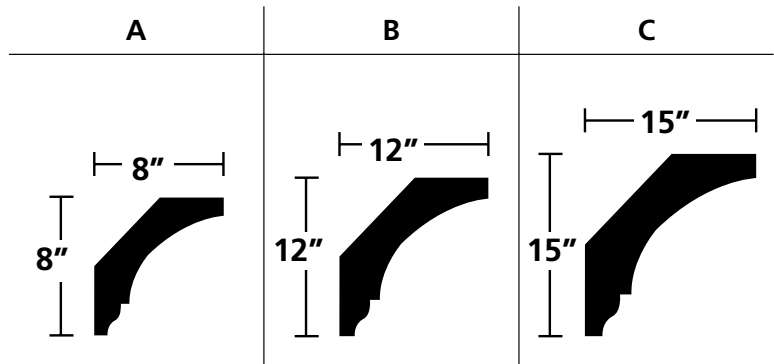

109

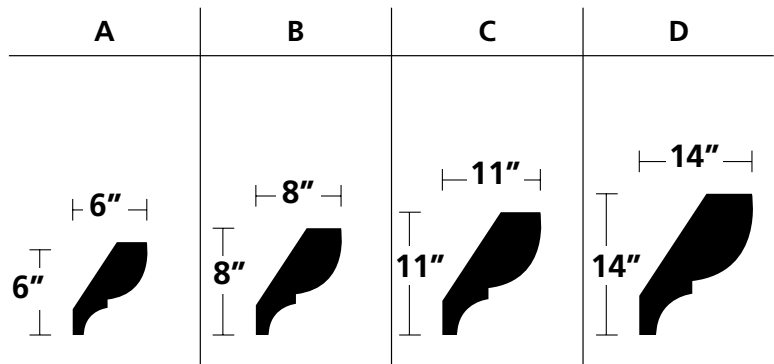

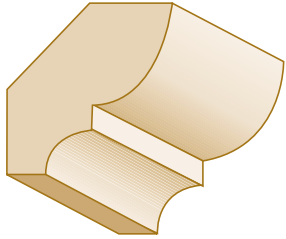
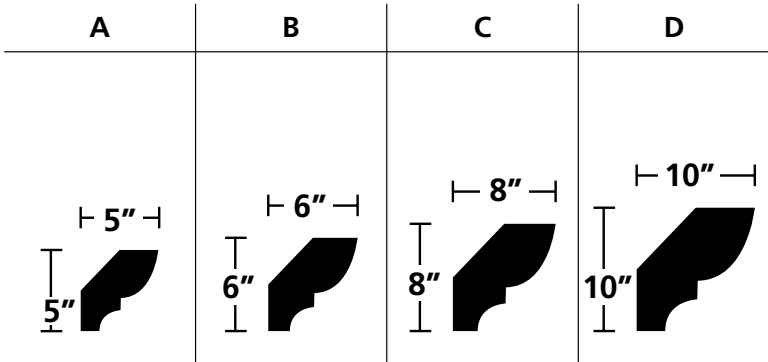

110

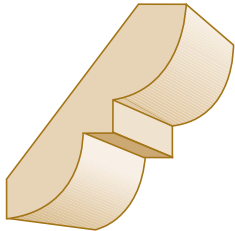
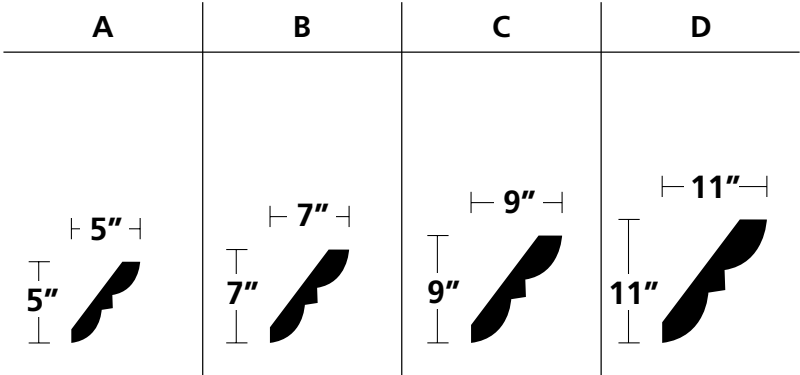

111

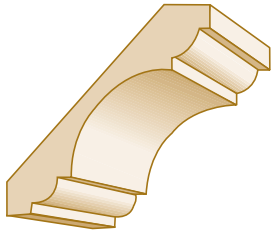
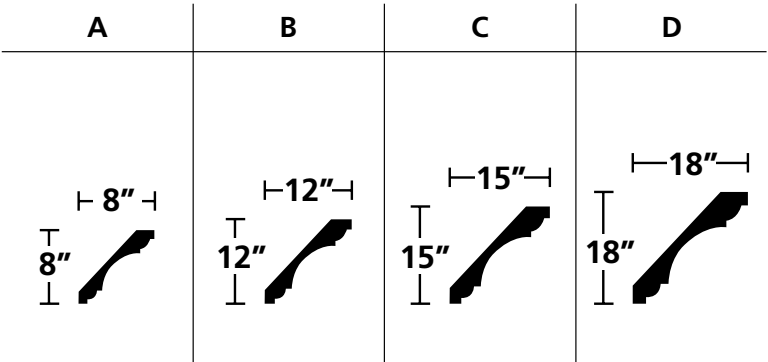

112

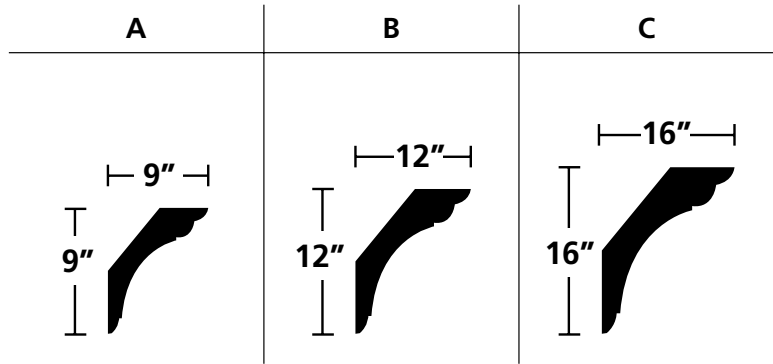
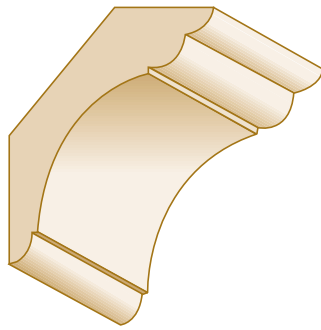

113

For fast and easy installations, inside and outside corners are available for all molding profiles.

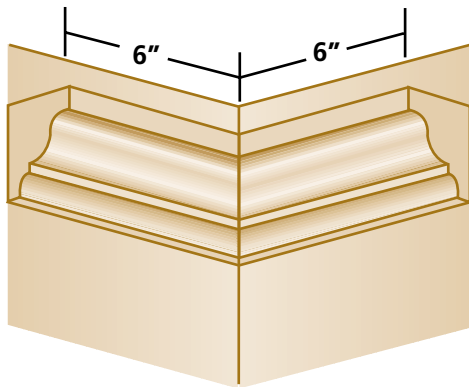

Prefabricated Inside Corner

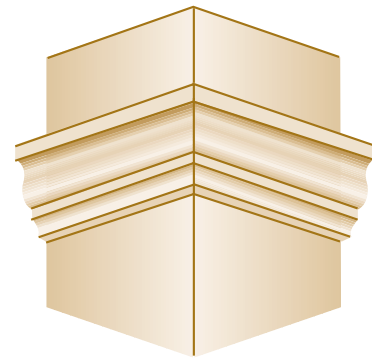

Prefabricated Outside Corner

Convex and concave curves can be made using most of our molding profiles. Specify radius when requesting a quote.

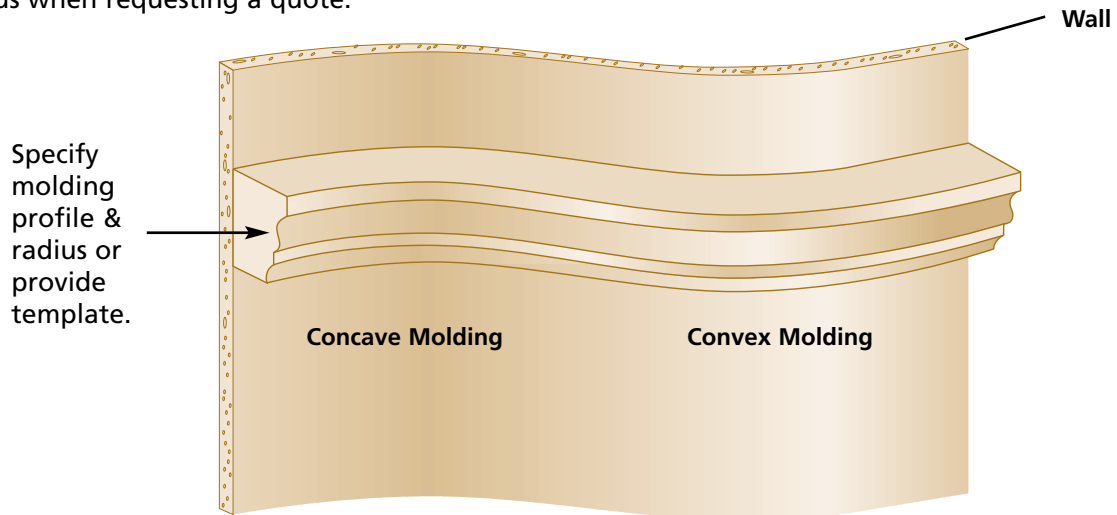

Cove Molding & Crown Molding are interchangeable. Product comes as notched or straight back as shown in catalog unless otherwise noted.

Cove Molding

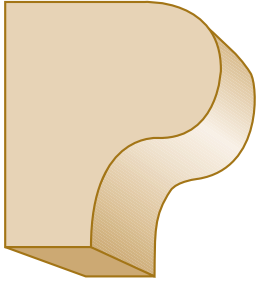
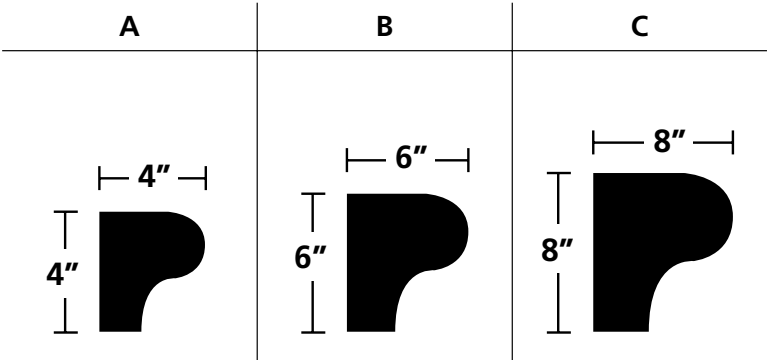

114

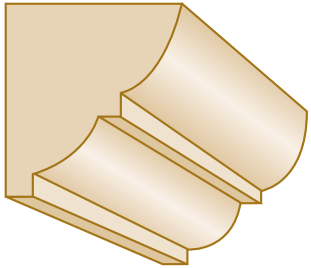
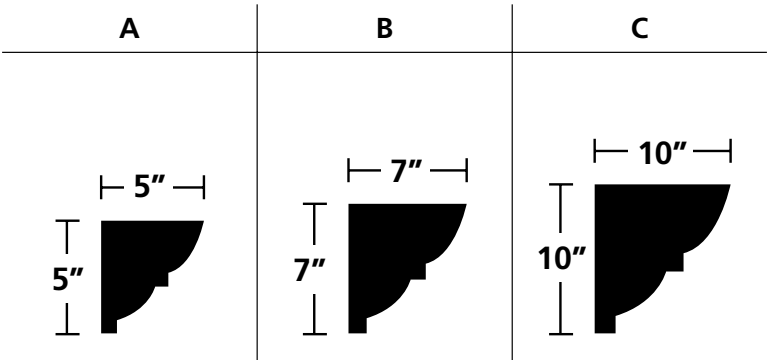

115

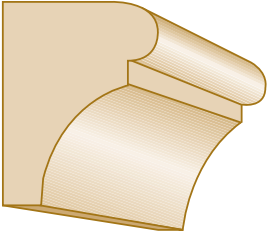
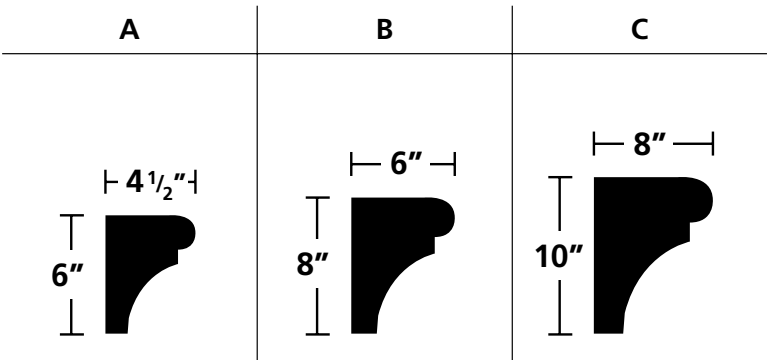

116

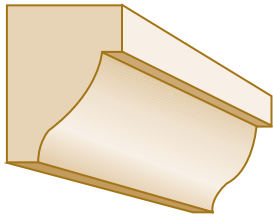

A	B	C	D

117

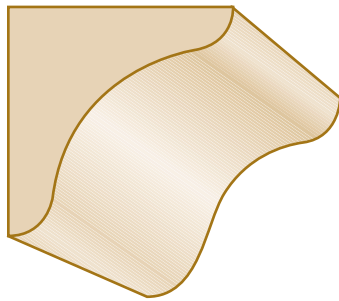

A	B	C	D

118

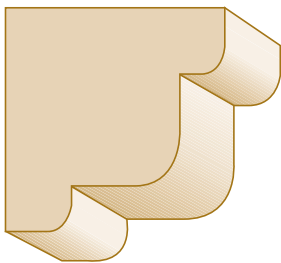

A	B	C	D

119

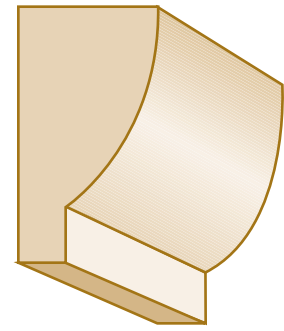
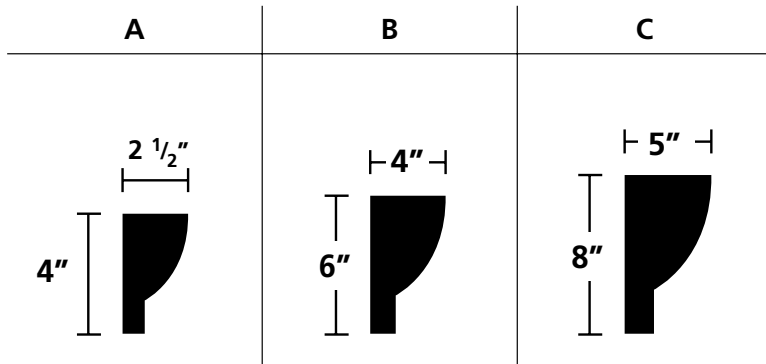

120

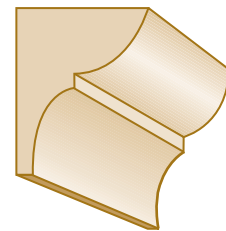
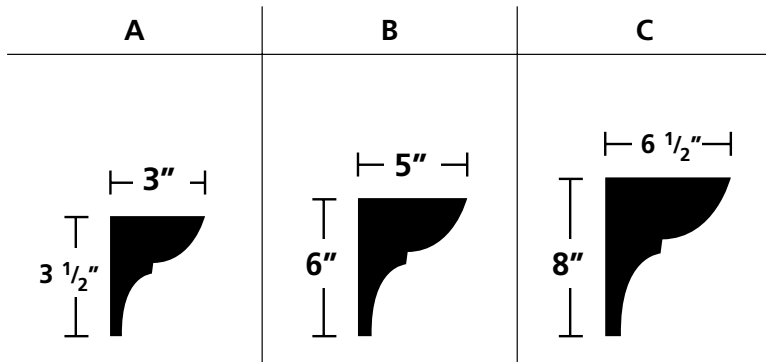

121

Cove moldings can be manufactured to accommodate lighting strips.

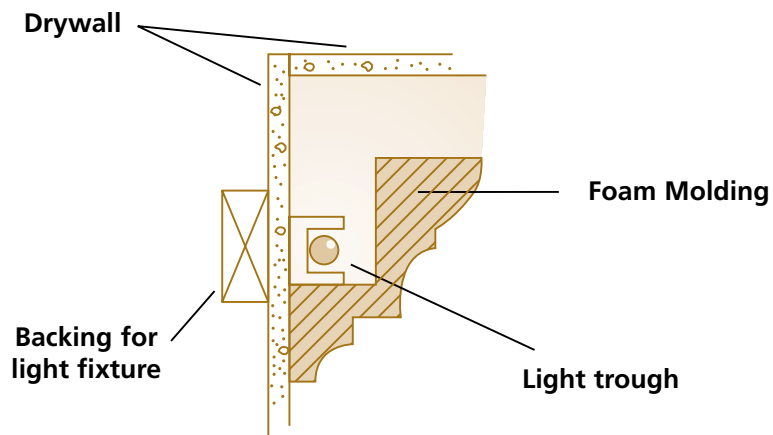

Casing and Trim

Suggested uses for these profiles include door and window casing, picture molding, chair rail, ceiling trim, etc.

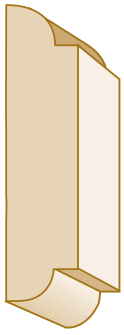

122

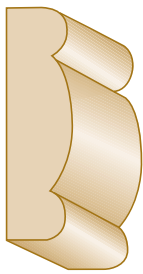
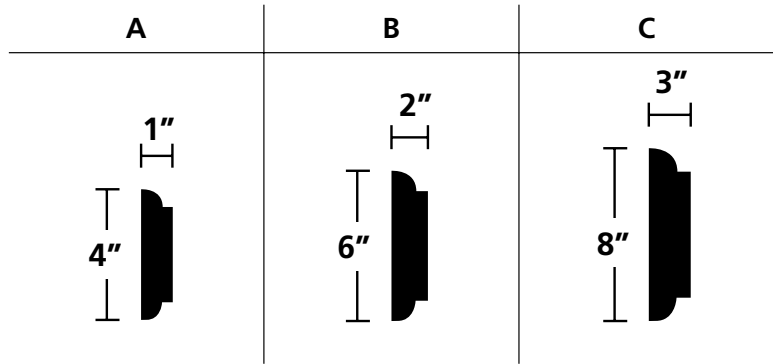

123

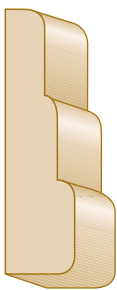
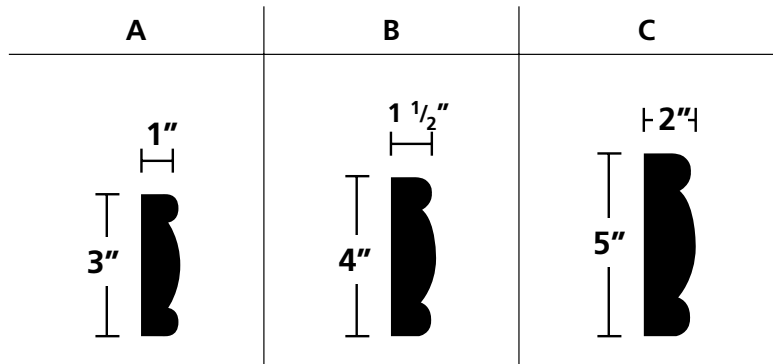

124

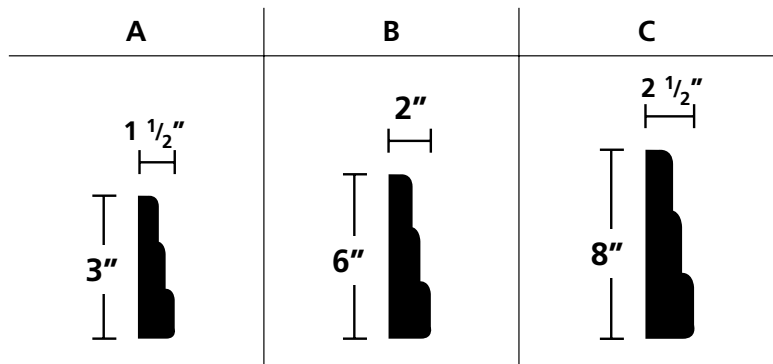

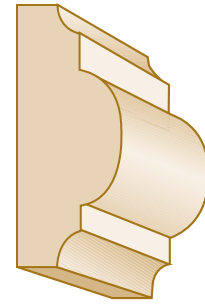
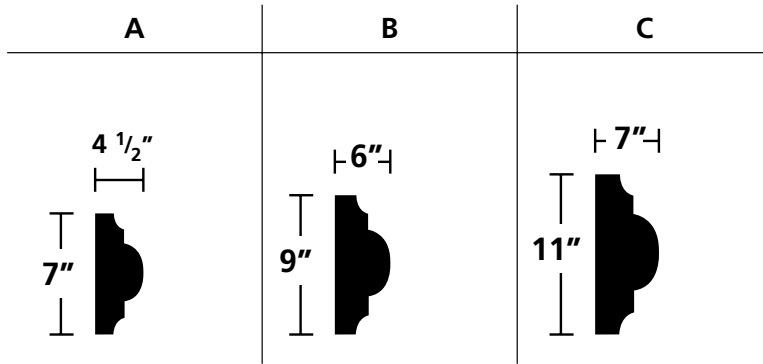

125

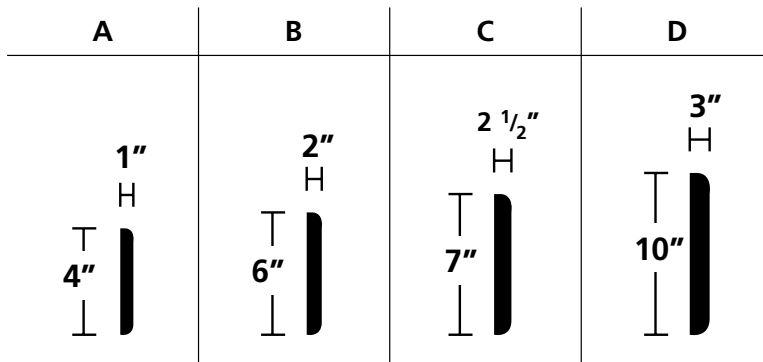

126

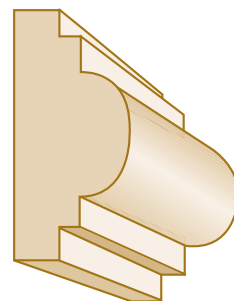
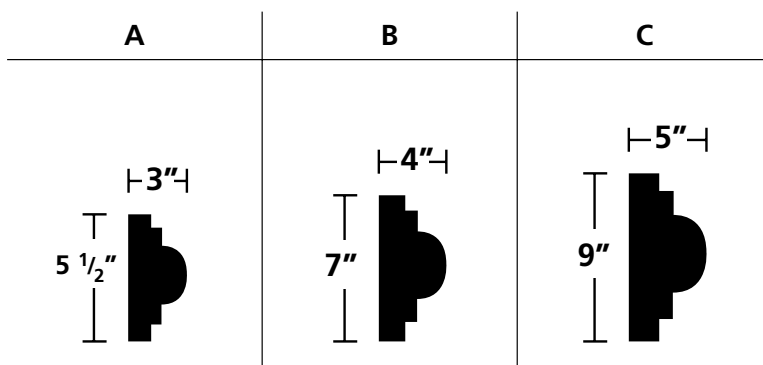

127

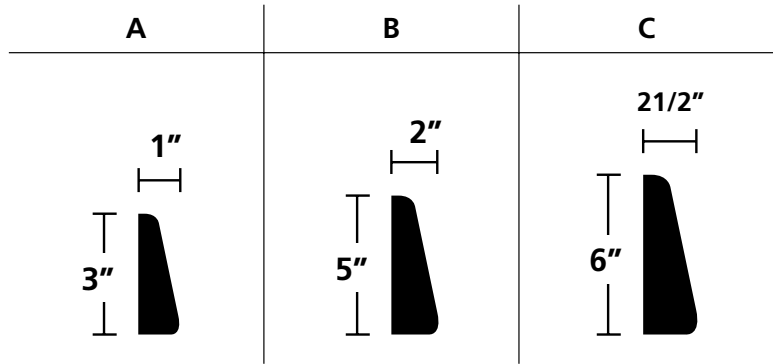
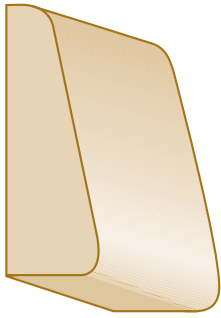

128

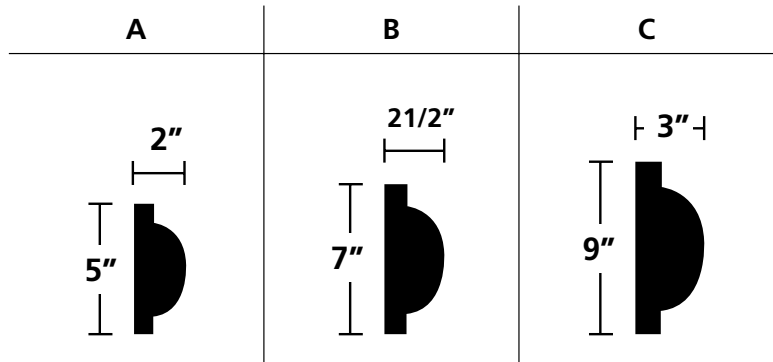
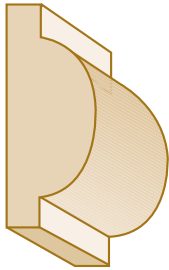

129

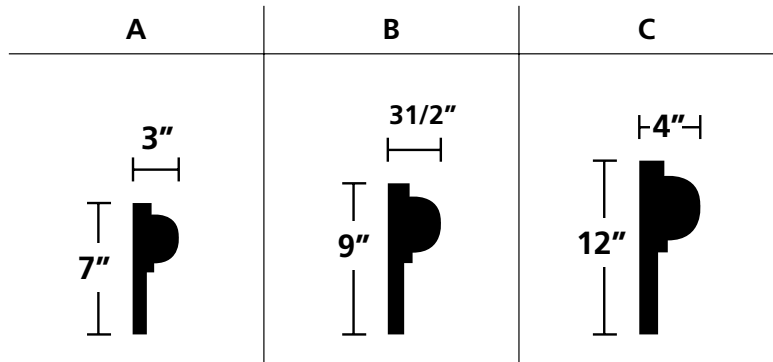
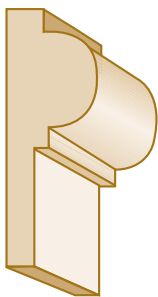

130

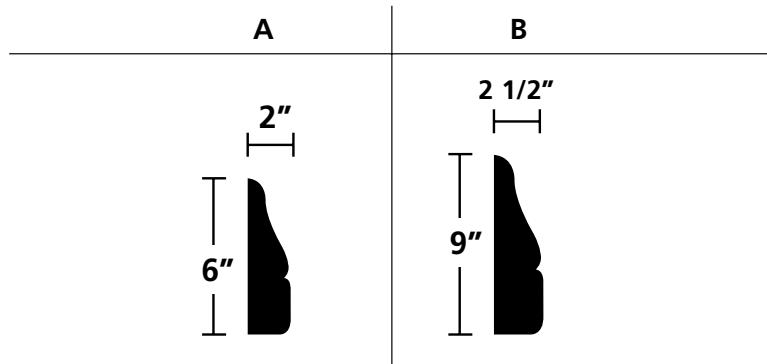

131

Custom Applications

Left and right returns are available to finish molding runs or for using molding for pot shelves or sill trim.

Door & Window Headers

Specify molding stock # and A & B dimensions.

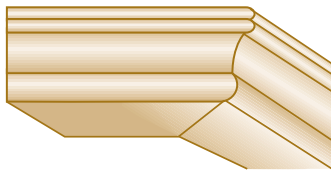

Right Return

Left Return

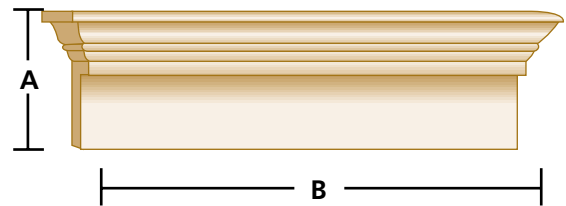
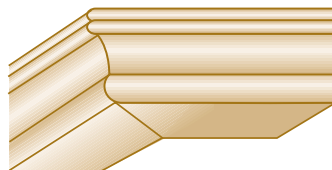

Case molding used for door or window casing.

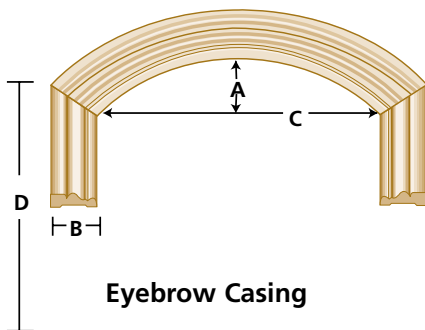

Eyebrow Casing

Specify dimensions A-D plus stock number

Elliptical Casing

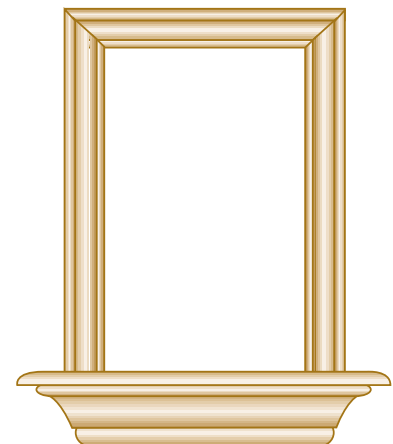
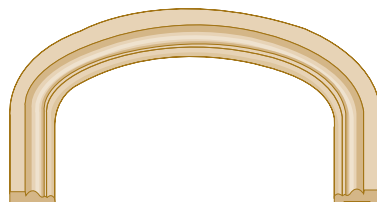

Typical column styles



**Tapered
Shaft**

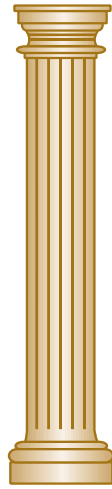

**Fluted
Shaft**

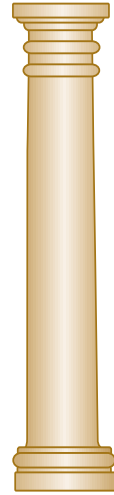

**Straight
Shaft**

Column Cross Section Top View

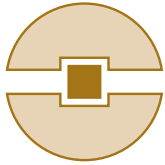

Full round column delivered in two halves with cut out for support post.

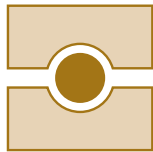

Square column with cut out for support post.



Solid pilaster, wall applied.

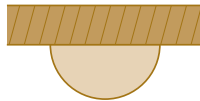

Solid half round column, wall applied.

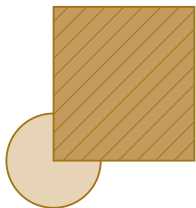

3/4 round column applied at corner.



Custom pilaster corner application.

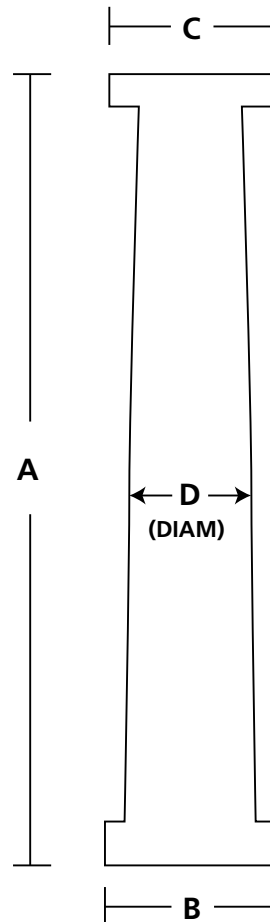

Specify dimensions (A - D) and style number.



Style 201

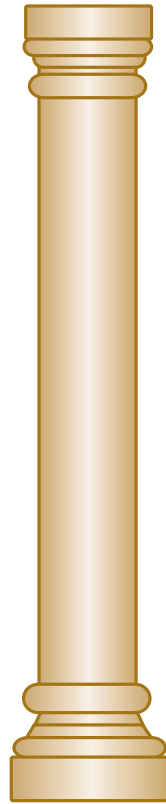

Style 202



Style 203



Style 204

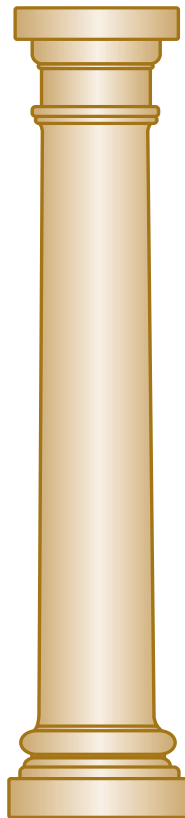

Style 205

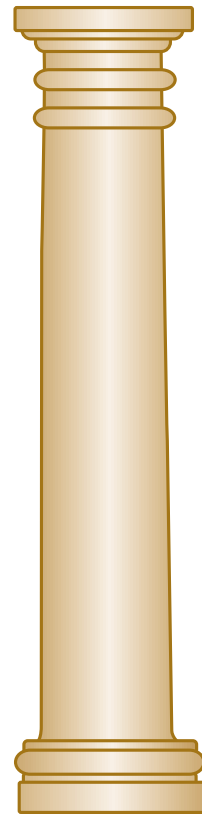

Style 206

Domes

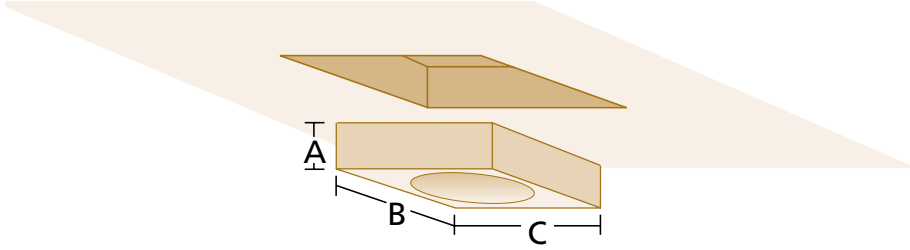

Specify style and dimensions A-C

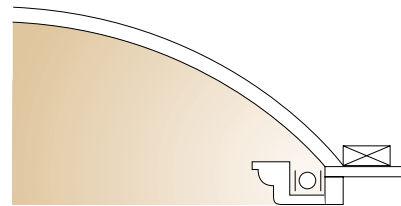
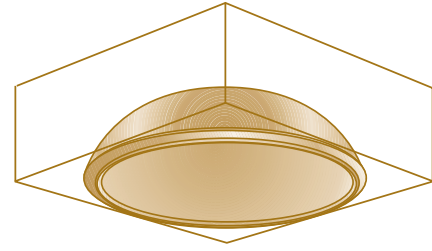

Light covers can be cut for any dome.

Niches

Specify dimensions of opening that will receive niche.

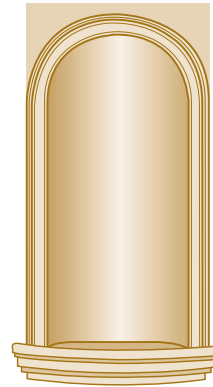
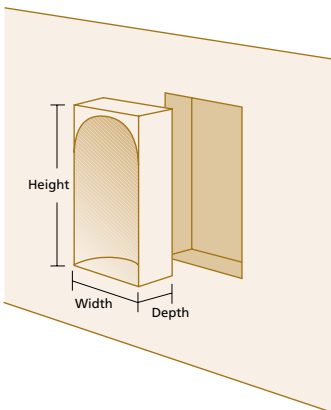

Style 401

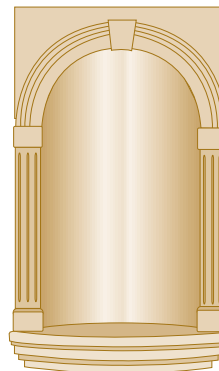

Style 402

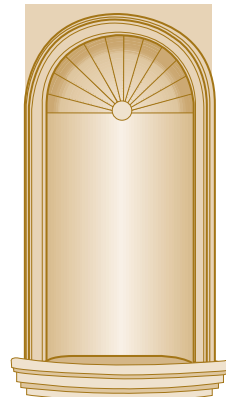

Style 403

To order surrounds pictured, fax dimensions A - F.
Grout lines are optional.

Style 301

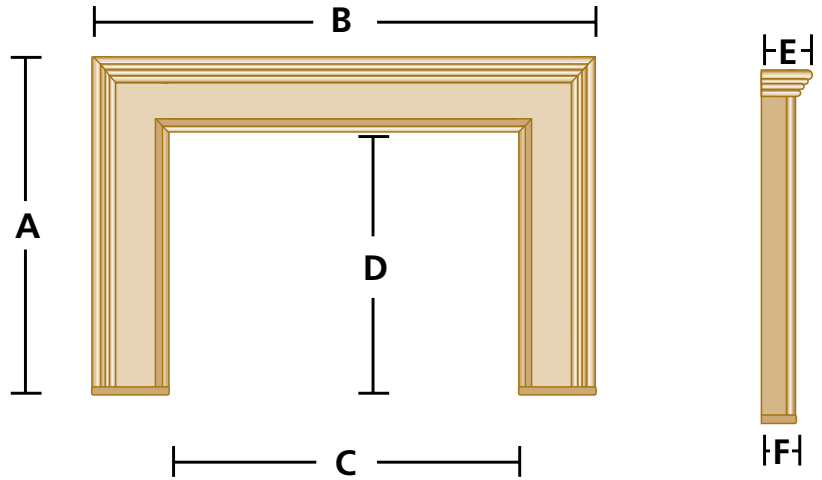

Style 302







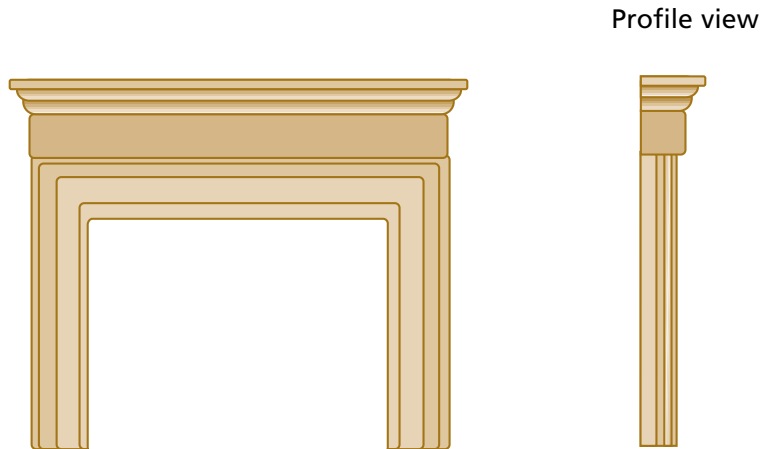









Custom Designs Welcome
Fax us a drawing or photo of
your fireplace surround,
we'll quote it quickly.

Style 303



Index

Standard #		Dimensions Available	Page #	Standard #		Dimensions Available	Page #
101		A - 6" x 6" B - 8" x 8" C - 12" x 12"	4	116		A - 6" x 4 1/2" B - 8" x 6" C - 10" x 8"	9
102		A - 6 x 5 B - 8" x 6 1/2" C - 10" x 8"	4	117		A - 4" x 2 1/4" B - 8" x 5 1/2" C - 12" x 8" D - 15" x 10"	10
103		A - 5" x 3" B - 7" x 5 1/2" C - 10" x 7"	4	118		A - 4" x 4" B - 6" x 6" C - 10" x 10" D - 14" x 14"	10
104		A - 4" x 4" B - 6" x 6" C - 8" x 8" D - 10" x 10"	5	119		A - 4" x 4" B - 5" x 5" C - 7" x 7" D - 10" x 10"	10
105		A - 4" x 4" B - 6" x 6" C - 9" x 9" D - 12" x 12"	5	120		A - 4" x 2 1/2" B - 6" x 4" C - 8" x 5"	11
106		A - 4" x 4" B - 6" x 6" C - 8" x 8" D - 12" x 12"	5	121		A - 3 1/2" x 3" B - 6" x 5" C - 8" x 6 1/2"	11
107		A - 6" x 8" B - 8" x 11" C - 12" x 16"	6	122		A - 4" x 1" B - 6" x 2" C - 8" x 3"	12
108		A - 8" x 8" B - 12" x 12" C - 15" x 15"	6	123		A - 3" x 1" B - 4" x 1 1/2" C - 5" x 2"	12
109		A - 6" x 6" B - 8" x 8" C - 11" x 11" D - 14" x 14"	6	124		A - 4" x 1 1/2" B - 6" x 2" C - 8" x 2 1/2"	12
110		A - 5" x 5" B - 6" x 6" C - 8" x 8" D - 10" x 10"	7	125		A - 7" x 4 1/2" B - 9" x 6" C - 11" x 7"	13
111		A - 5" x 5" B - 7" x 7" C - 9" x 9" D - 11" x 11"	7	126		A - 4" x 1" B - 6" x 2" C - 7" x 2 1/2" D - 10" x 3"	13
112		A - 8" x 8" B - 12" x 12" C - 15" x 15" D - 18" x 18"	7	127		A - 5 1/2" x 3" B - 7" x 4" C - 9" x 5"	13
113		A - 9" x 9" B - 12" x 12" C - 16" x 16"	8	128		A - 3" x 1" B - 5" x 2" C - 6" x 2 1/2"	14
114		A - 4" x 4" B - 6" x 6" C - 8" x 8"	9	129		A - 5" x 2" B - 7" x 2 1/2" C - 9" x 3"	14
115		A - 5" x 5" B - 7" x 7" C - 10" x 10"	9	130		A - 7" x 3" B - 9" x 3 1/2" C - 12" x 4"	14
				131		A - 6" x 2" B - 9" x 2 1/2"	15